

Commercial pumps **HYDROSTAR PLUS 1450**

Hydrostar Plus 1450 pumps incorporate the latest technology in design and construction to produce a high performance, energy-saving pump ideal for any situation that demands maximum output.



For commercial pools, aquatic parks, and seawater facilities.

Waterco's pump's unique construction offers several advantages compared to steel pumps. Glass reinforced thermoplastic possesses superior mechanical and chemical resistance to steel.

Hydrostar Plus 1450

Hydrostar Plus 1450 pumps are high-performance corrosion-resistant thermoplastic pumps equipped with a 6" flanged inlet port and 4" flanged outlet port. The pump's 4 pole motor runs at 1450 rpm making them ideal for high water flow applications such as aquatic facilities, water parks and large commercial swimming pools.

Hydrostar Plus 1450 pump's main body is constructed from an injection moulded glass reinforced thermoplastic. Glass reinforced thermoplastic possesses superior mechanical and chemical resistance to steel.

Construction Materials

Item	Material
Motor Bracket	Polypropylene + GF
Pump Bracket	Polypropylene + GF
Pump Body	Polypropylene + GF
Pump Body (O Ring)	NBR
Seal Assembly	Alumina Ceramic/SS316/Carbon(*)
Impeller	Noryl + GF
Diffuser	Polypropylene + GF
Lock Ring	Noryl + GF

(*) Silicon Carbide optional

Lid

- Clear polycarbonate strainer lid
- Instant view of the strainer basket
- Lock ring with easy grip handles for easy maintenance
- Pressure relief valve

Discharge Port

- 4" JIS flange

Impeller

- CFD Designed
- Glass filled Noryl for long lasting reliability

Shaft Sleeve

- Corrosion resistance 431 stainless steel

Motor

- Heavy duty IP55 weather proofed 4 pole motor
- VSD compatible
- IE 3 Class

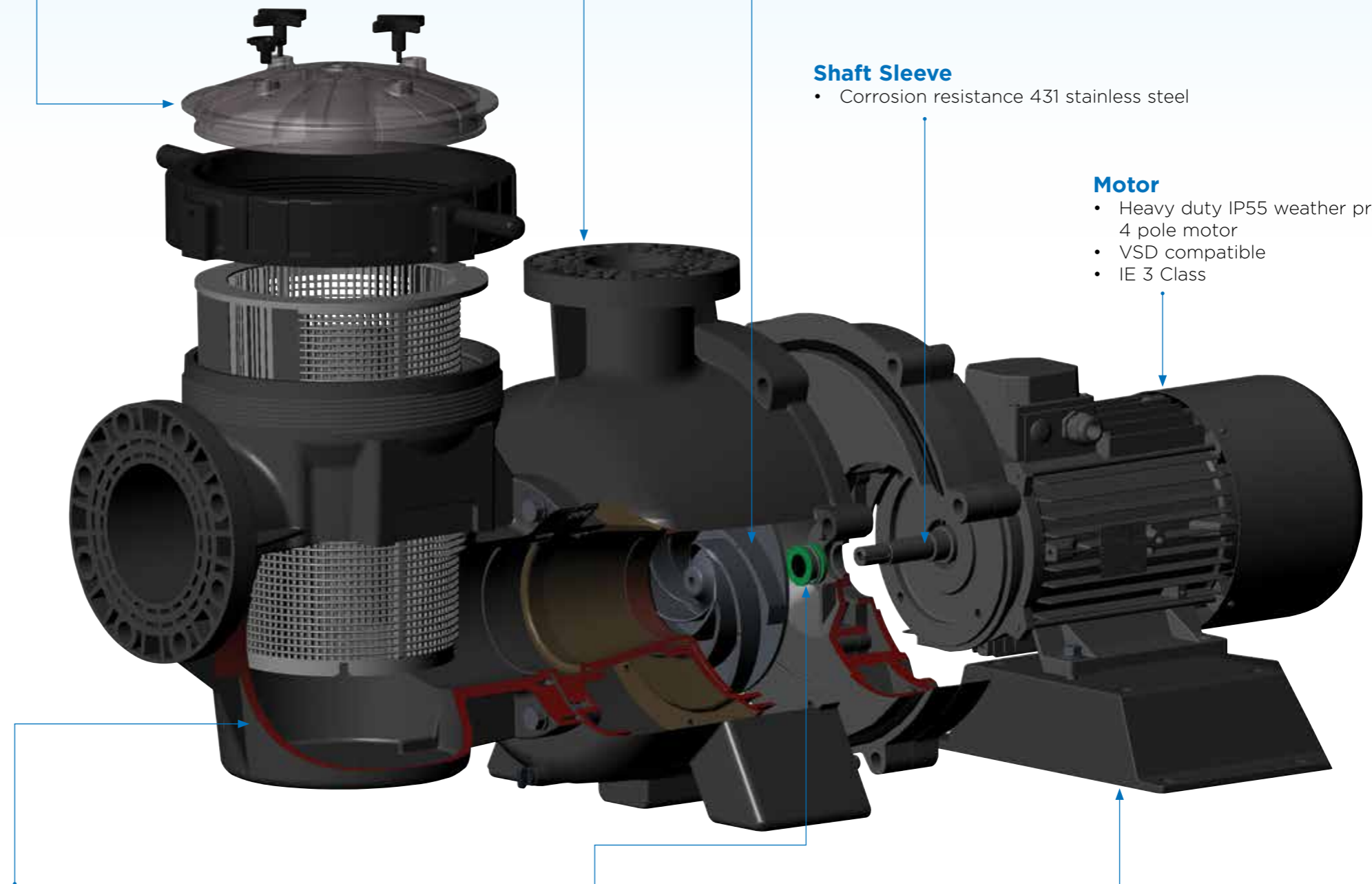

Basket Strainer

- Corrosion free glass reinforced thermoplastic
- UV stabilised
- Molded 17L polypropylene basket (FDA-grade)
- 6" ANSI flange suction port
- Max flow rate 2450 lpm (147 m³/hr) (647 US GPM)

Mechanical Seals

- Self-lubricating mechanical seals
- Marine grade seal also available

Base

- Glass reinforced moulded base for ease of mounting
- Designed to improve stability

Technical Specifications (with Strainer)

Model	Pump Input Power		Amps/Phase	Weight (kg)	Total Length (mm)	Motor input power (kW)	Motor I _{max} (Amp)	Q _{max} (m ³ /h)	H _{max} (m)
	(kW)	(HP)							
3.7kW	4.16	5.57	8.7	89	1236	4.19	8.7	105.2	17.9
5.5kW	5.75	7.70	11.8	96	1274	6.14	11.8	125.8	19.1
7.5kW	7.76	10.40	16.3	112	1340	8.30	16.1	147.2	20.7

Technical Specifications (without Strainer)

Model	Pump Input Power		Amps/Phase	Weight (kg)	Total Length (mm)	Motor input power (kW)	Motor I _{max} (Amp)	Q _{max} (m ³ /h)	H _{max} (m)
	(kW)	(HP)							
3.7kW	4.15	5.56	8.8	73	729	4.19	8.7	107.6	18.0
5.5kW	5.64	7.60	11.6	80	767	6.14	11.8	129.5	19.3
7.5kW	7.86	10.50	16.3	96	833	8.30	16.1	152.3	21.0

Phase	Volts	Cycle	RPM	Motor IP Rating	Pump IP Rating
3	400	50Hz	1450	IP55	X5

Pump Dimensions With Strainer (mm)

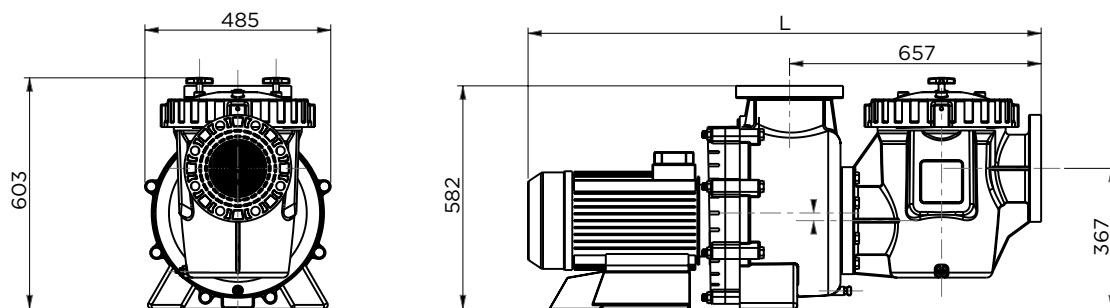

Pump Model	L (mm)
3.7kW	1236
5.5kW	1274
7.5kW	1340

Pump Dimensions Without Strainer (mm)

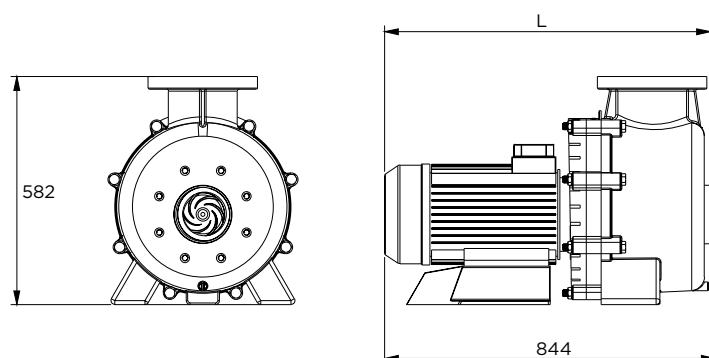

Pump Model	L (mm)
3.7kW	729
5.5kW	767
7.5kW	833

Performance Curves

Hydrostar Plus 1450 (with Strainer)

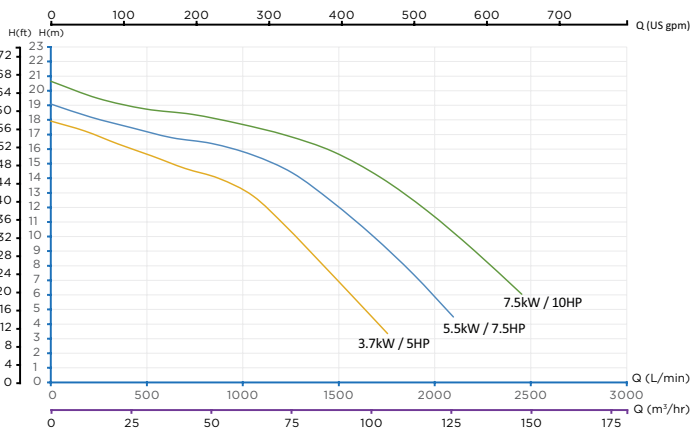

Hydrostar Plus 1450 (without Strainer)

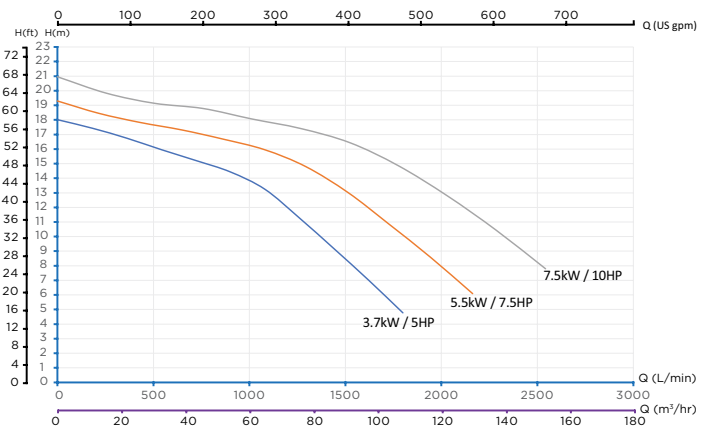

Noise Level

Hydrostar Plus 1450 (with Strainer)

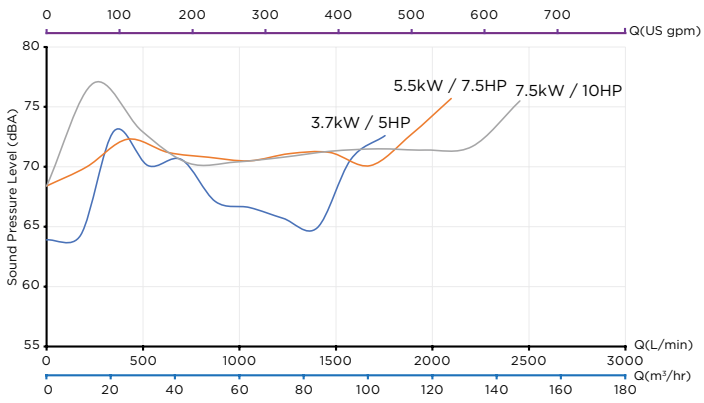

Hydrostar Plus 1450 (without Strainer)

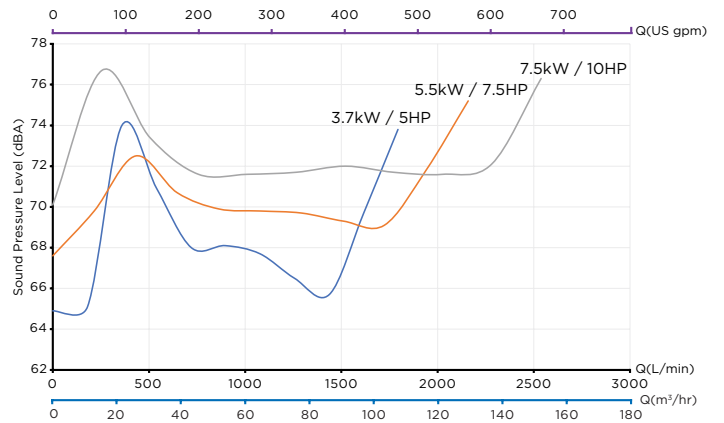

Hydrostar Plus 1450 - Models Available

P/N	Description	Power	Flanges	Seal Type	Strainer
24705004	HYDROSTAR PLUS 1450 3.7kW	3.7kW/5.0HP	4" JIS / 6" ANSI	Standard Seal	Included
24707504	HYDROSTAR PLUS 1450 5.5kW	5.5kW/7.5HP	4" JIS / 6" ANSI	Standard Seal	Included
24710004	HYDROSTAR PLUS 1450 7.5kW	7.5kW/10HP	4" JIS / 6" ANSI	Standard Seal	Included
2470501	HYDROSTAR PLUS 1450 3.7kW	3.7kW/5.0HP	-	Standard Seal	Not Include
2470751	HYDROSTAR PLUS 1450 5.5kW	5.5kW/7.5HP	-	Standard Seal	Not Include
2471001	HYDROSTAR PLUS 1450 7.5kW	7.5kW/10HP	-	Standard Seal	Not Include
12161002	HYDROSTAR PLUS FLANGE KITS Flange Kits				

Commercial Pumps Warranty - Commercial Applications

Conditions	Warranty Period
Wet ends	2 years
Hair & lint pot lid, o'ring, basket, impeller & diffuser	2 years
Motor and mechanical seal	1 year

Company Profile

Waterco pioneers reliable solutions for healthy, safe water environments, which are used in residential, commercial and industrial applications in over 40 countries.

Established in 1981 in Sydney, Australia, it has since become a global brand recognised for designing and manufacturing filtration and sanitisation innovations for the swimming pool, spa, aquaculture, and water purification sectors.



CONTACT WATERCO

Waterco's head office is situated in Sydney, Australia with international offices, manufacturing plants and warehouses located in Australia, New Zealand, Malaysia, Indonesia, Singapore, China, the US, Canada, and the UK.

OFFICES - AUSTRALIA

NSW - Sydney (Head Office)
Tel: +61 2 9898 8600

QLD - Brisbane
Tel: +61 7 3299 9900

VIC/TAS - Melbourne
Tel: +61 3 9764 1211

WA - Perth
Tel: +61 8 9273 1900

SA/NT - Adelaide
Tel: +61 8 8244 6000

ACT Distribution
Tel: +61 2 6280 6476

OFFICES - OVERSEAS

Waterco (Europe) Limited
Sittingbourne, Kent, UK
Tel: +44 (0) 1795 521 733

Waterco (USA) Inc
Augusta, Georgia, USA
Tel: +1 706 793 7291

Waterco Canada
Boucherville, Quebec, Canada
Tel: +1 450 748 1421

Waterco (NZ) Limited
Auckland, New Zealand
Tel: +64 9 525 7570

Waterco (C) Limited
Guangzhou, China
Tel: +86 20 3222 2180

Waterco (Far East) Sdn Bhd
Selangor, Malaysia
Tel: +60 3 6145 6000

PT Waterco Indonesia
Jakarta, Indonesia
Tel: +62 21 4585 1481

Waterco Singapore Intl Pte Ltd
Nehsons Building, Singapore
Tel: +65 6344 2378

DISTRIBUTED BY:

WATERCO
water, the liquid of life



ZZB2034 09/20